



Vaisala Present Weather and Visibility Sensors PWD10, PWD12, PWD20, PWD22



A sensor family that grows with your needs

Off-the-Shelf Accuracy and Reliability.

Thousands of Vaisala present weather and visibility sensors are installed around the world, working reliably and accurately in diverse applications and climates. In the Vaisala PWD-series of present weather detectors and visibility sensors, you will find the mix you require of visibility measurement range (MOR), characterization of reduced visibility, precipitation type identification, precipitation accumulation/intensity measurement, and report formats (WMO, NWS code tables).

Proven measurement principles

The Vaisala Present Weather Detectors PWD12 and PWD22 identify precipitation type by accurately estimating the water content of precipitation with a capacitive device (Vaisala RAINCAP® sensor element) and combining this information with optical forward scatter and temperature measurements. These three independent measurements are processed through sophisticated algorithms in order to produce an accurate evaluation of the weather type according to the WMO and NWS code tables.

Accurate visibility measurement

Calibrated with reference to a highly accurate transmissometer, Vaisala PWD-series sensors use the proven forward-scatter measurement principle to measure Meteorological

Optical Range (MOR). The visibility sensor is well-protected against contamination: the optical components point downwards and hoods protect the lenses against precipitation, spray and dust. This weather-proof design of the PWD sensors provides accurate measurement results and reduces the need for maintenance. The optional hood heaters are recommended for wintry conditions to prevent ice and snow accumulation.

Economical visibility measurement for road weather applications

With a measurement range of 10–2,000 meters, the Vaisala Visibility Sensor PWD10 offers economical and reliable visibility measurement for road weather applications. The PWD10 is recommended for road weather systems which alert drivers to e.g. reduced visibility.

Vaisala Present Weather Detector PWD22.

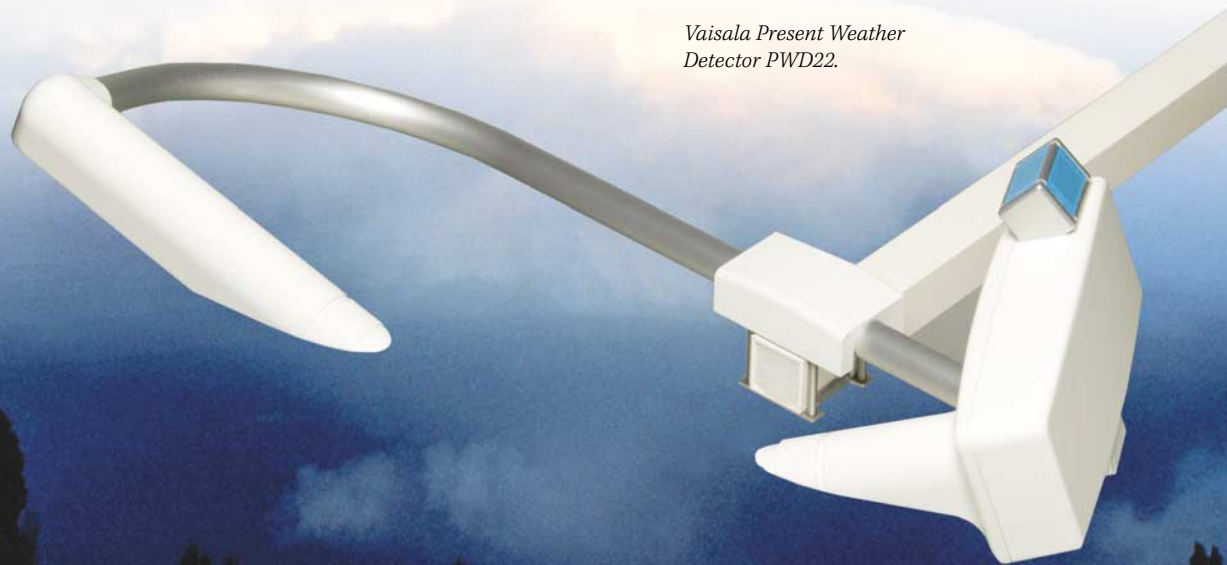



The optional Vaisala Luminance Sensor PWL111 provides the background luminance information needed for aeronautical visibility reporting in AWOS use. The PWL111 can be used as a day/night switch or in continuous luminance measurement mode.

For sophisticated road weather applications

The Vaisala Present Weather Detector PWD12 provides accurate visibility and present weather measurement in the road environment, where low visibility is a serious safety hazard and significantly reduces traffic flow rates. With a visibility measurement range of 10–2,000 meters, the Vaisala Present Weather Detector PWD12 is ideal for road weather applications. The PWD12 also indicates the cause of reduced visibility to give you a full picture of weather conditions. Its ability to detect precipitation and identify precipitation type gives the road authority valuable information for the short-range planning of road maintenance operations.

For meteorological and aviation applications

With a visibility measurement range of 10–20,000 meters, the Vaisala Present Weather Detector PWD22 is a two-in-one forward scatter visibility and present weather sensor. The PWD22 is recommended for automatic weather stations (especially low-power AWSs) that are used for general meteorological and aviation applications. The PWD22's ability to detect freezing precipitation makes it possible to issue warnings when the weather presents safety hazards for road and air traffic.

The PWD22 is equipped with two Vaisala RAINCAP® sensor elements to improve detection sensitivity during light precipitation events – even light drizzle is detected. The PWD22 also reports present weather in WMO METAR code format so it is easily integrated with AWOS systems.

Wherever visibility measurement is needed

With a measurement range of 10–20,000 meters, the Vaisala Visibility Sensor PWD20 offers long-range visibility measurement for diverse applications covering harbors, coastal areas, heliports, windmill parks – indeed, any locations or areas where visibility measurement is necessary.

Easy installation

PWD sensors are less than one meter long. All are compact, light-weight, come with a cable and connector for easy installation, and can be mounted in many ways on any existing mast.

Expandable measurement capabilities

The measurement capabilities of the Vaisala PWD-series sensors can be extended when your measurement needs grow. All PWD-series sensors can be economically upgraded to ensure that your PWD sensor gives full value for many years to come.

Technical Information

Present weather

PWD12	
Identifies	4 different types of precipitation (rain, drizzle, mixed rain/snow, snow) Fog, mist, haze (smoke, sand) or clear
Reports	WMO 4680 (SYNOP) and NWS code tables 39 different codes supported from WMO 4680 code table
PWD22	
Identifies	7 different types of precipitation (rain, freezing rain, drizzle, freezing drizzle, mixed rain/snow, snow, ice pellets) Fog, mist, haze (smoke, sand) or clear
Reports	WMO 4680 (SYNOP), 4678 (METAR) and NWS code tables 49 different codes supported from WMO 4680 code table

Precipitation measurement

Measures	Precipitation intensity, accumulation and amount of new snow
Precipitation detection sensitivity	0.05 mm/h or less, within 10 minutes

Visibility measurement

Operating principle	Forward scatter measurement
PWD10 and PWD12	
Measurement range (MOR)	10 ... 2000 m (32 ... 6500 ft)
PWD20 and PWD22	
Measurement range (MOR)	10 ... 20,000 m (32 ... 65,600 ft)
Accuracy	+/-10%, range 10 ... 10,000 m +/-15%, range 10 ... 20 km

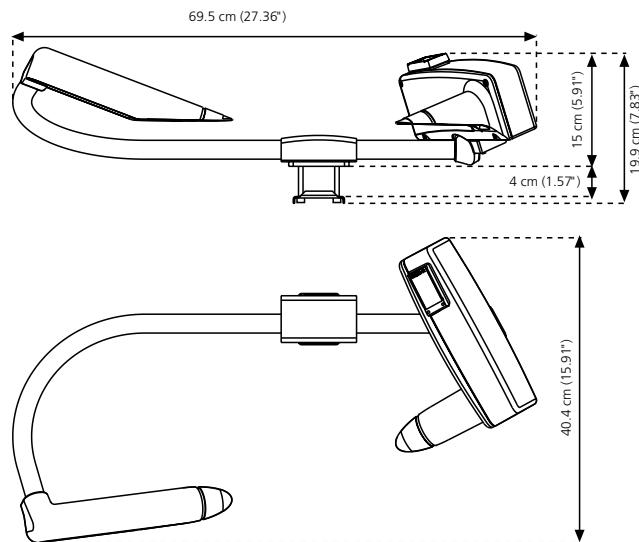

Electrical

Power supply	12 V DC ... 50 V DC (electronics) 24 V AC or 24 V DC for heater option
Power consumption	
PWD10 and PWD20	3 W (electronics with dew heaters @12VDC)
PWD12 and PWD22	6 W
Options	2 W (luminance sensor with dew heater) 65 W (heater option)
Outputs	RS-232, RS-485 Three programmable relay controls, visibility alarm threshold and delays configurable, fault alarm relay 0 ... 1mA, 4 ... 20 mA analog current

Mechanical

Dimensions	40.4 (w) x 69.5 (l) x 19.9 (h) cm 15.91" (w) x 27.36" (l) x 7.83" (h)
Weight	3 kg 6.61 lb

Environmental

Operating temperature	-40 ... +60 °C
Operating humidity	0 ... 100%RH
Protection class	IP66

Electromagnetic compatibility

CE-compliant	
Compliance has been verified according to the following EMC directives	
Verification subject	Standard
Radiated emissions	CISPR 16-1,16-2
Radiated susceptibility	IEC 61000-4-3,10 V/m
Conducted emissions	CISPR 16-1,16-2
Conducted susceptibility	IEC 61000-4-6
EFT immunity	IEC 61000-4-4
ESD immunity	IEC 61000-4-2
Surge	IEC 61000-4-5

Accessories/options

Luminance sensor PWL111 for AWOS applications
Hood heaters for winter conditions
Support arm for mast installations
Pole clamp kit for mast top installations
Calibration set PWA11
Maintenance cable 16385ZZ